

Current Technology Status and Future Needs For Rare Earth Permanent Magnets For Industrial Applications

**John Ormerod
Magnet Applications, Inc.**



Outline

- **Markets And Applications**
- **PM Principles – Back to Basics**
- **REPM History**
- **Current Materials And Technologies.**
 - **Powder Metallurgy**
 - **Melt Spinning**
 - **Dy Diffusion**
 - **Hot Pressing**
 - **SmFeN**
 - **La-Co Ferrite**
- **Future trends**
 - **Toyota**
 - **3D Printing**
- **Final thoughts**



“The Nation That Controls Magnetism Will Control The Universe”



- Dick Tracy cartoon strip, created by Chester Gould.
- Circa early-1960's i.e. before rare earth magnets and the Chinese dominance of RE supply chain and magnet industry!



Outline

- **Markets And Applications**
- **PM Principles – Back to Basics**
- **REPM History**
- **Current Materials And Technologies.**
 - **Powder Metallurgy**
 - **Melt Spinning**
 - **Dy Diffusion**
 - **Hot Pressing**
 - **SmFeN**
 - **La-Co Ferrite**
- **Future trends**
 - **Toyota**
 - **3D Printing**
- **Final thoughts**



History of Permanent Magnet Development

Is It Time For A New Breakthrough?

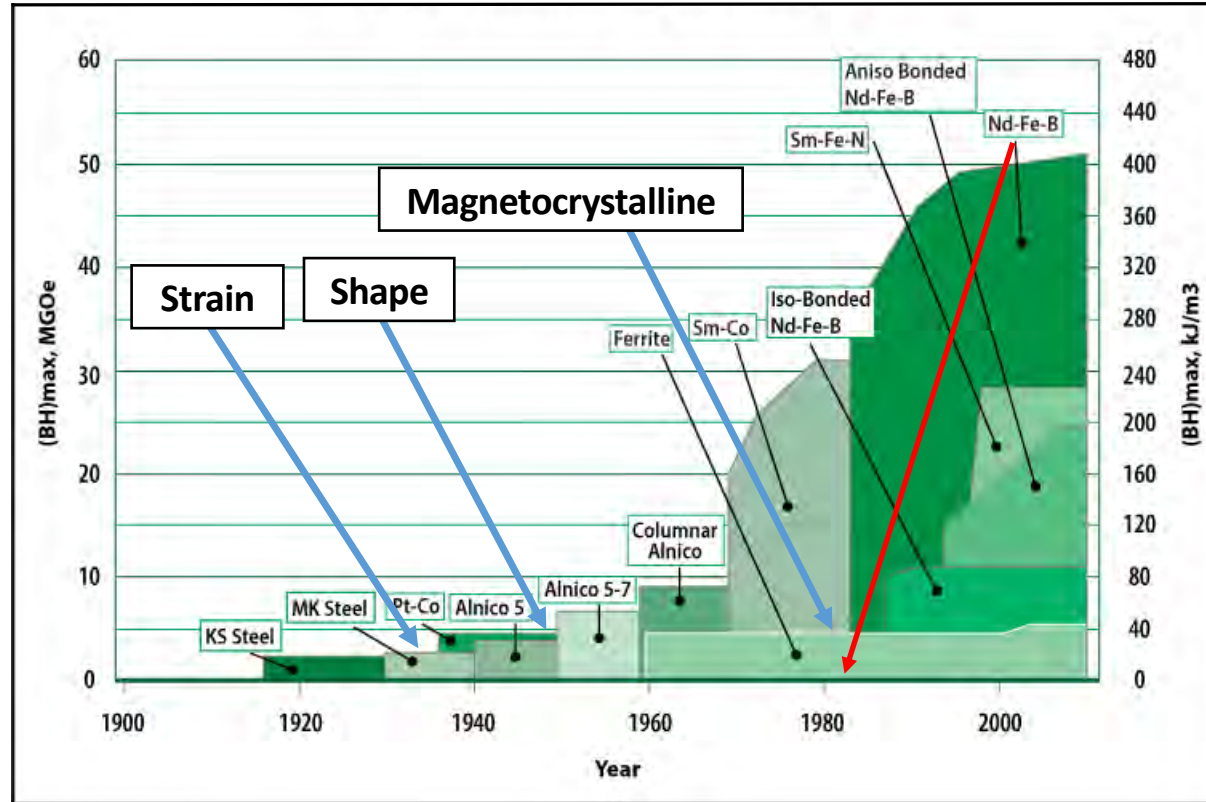

Commercially Important Permanent Magnets

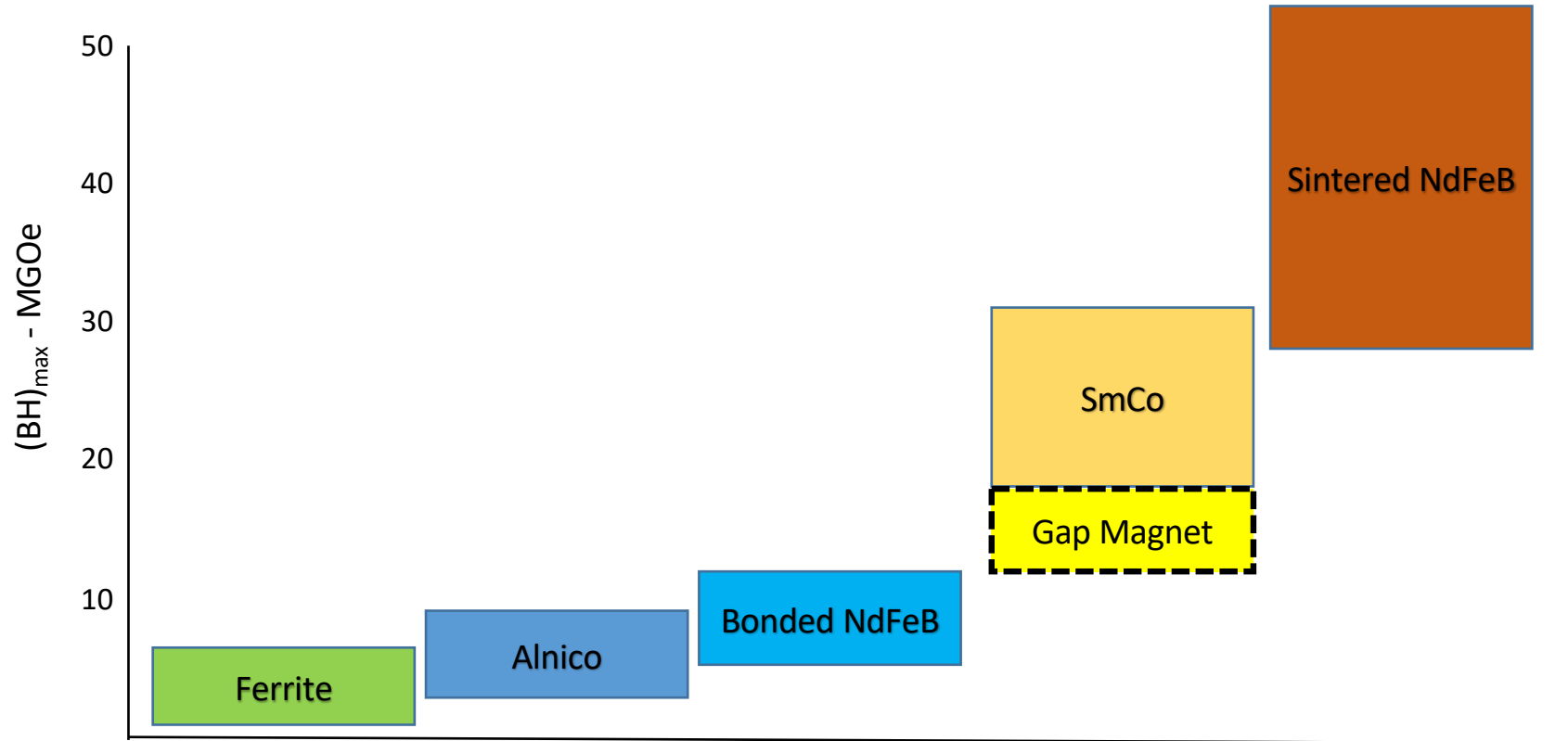

Estimated Permanent Magnet Market - 2016

Material	Weight (000's kg)	Value (\$ Millions)
NdFeB	137,500	10,300
Ferrite	750,000	5,300
Bonded NdFeB	10,000	900
SmCo	4,000	400
Alnico	6,000	350
	Total	Approximately \$17 B



Market (\$) Dominated By NdFeB And Ferrite

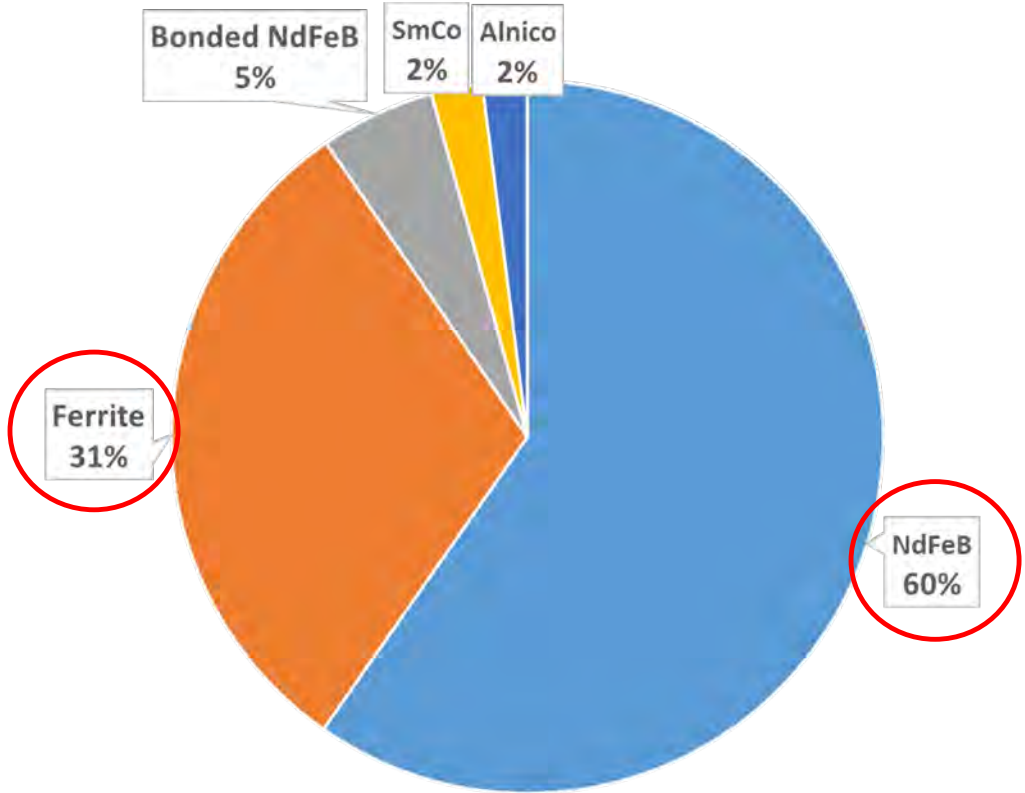

Major Functions Of A Magnet

Application Category	Physical Law	System Function is Proportional to	Application Examples
Electrical to Mechanical (with solid conductor)	Lorentz Force law	B	Loudspeakers, PM motors, HDD/ODD VCM
Mechanical to Electrical	Faraday's Law of Induced voltage	B	Generators, Alternator, Tachometer, Magneto, Microphone, Eddy current devices, sensors
Magnetostatic Field Energy to Mechanical Work	Coulomb Force Principles	B ²	Magnetic Chucks, Conveyors, Magnetic Separators, Reed Switches, Synchronous Torque Couplings
Electrical to Mechanical (with free charged particles)	Lorentz Force law	B	Travelling Wave Tubes, Magnetrons, Klystrons, MRI



Market By Major Application Type

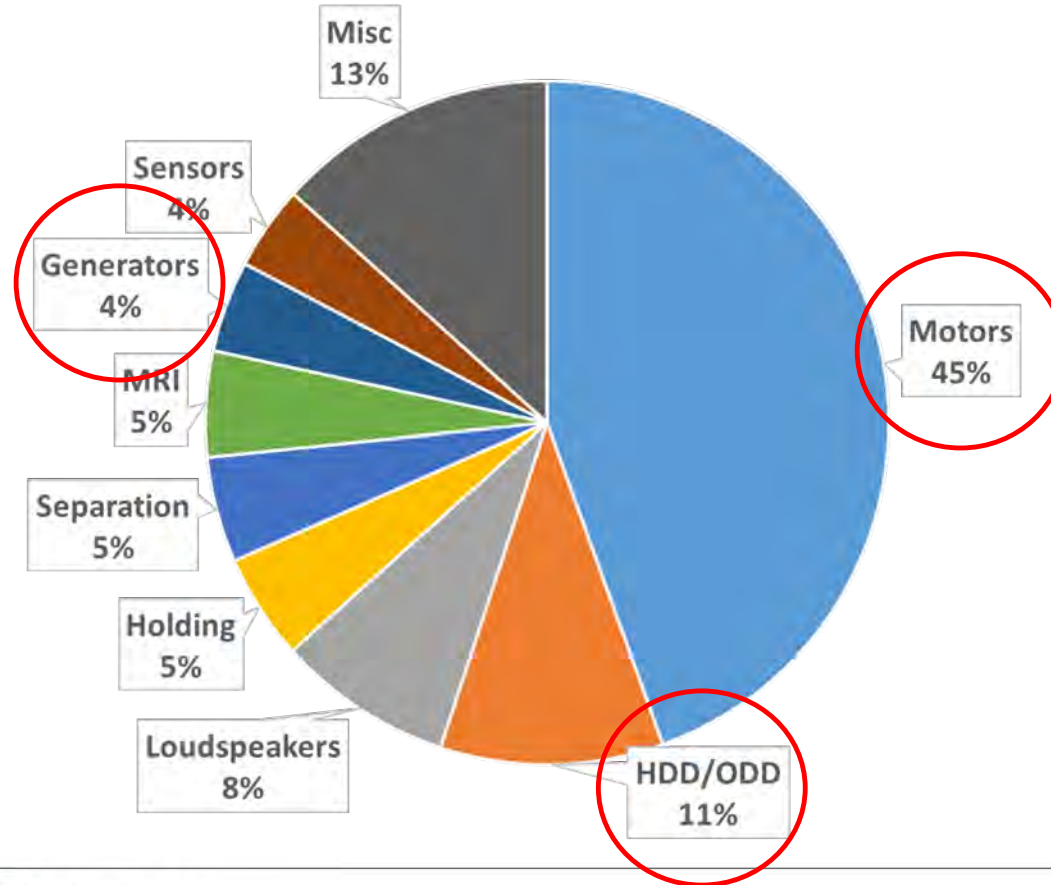

Automotive Applications – NdFeB Is Gaining Ground!

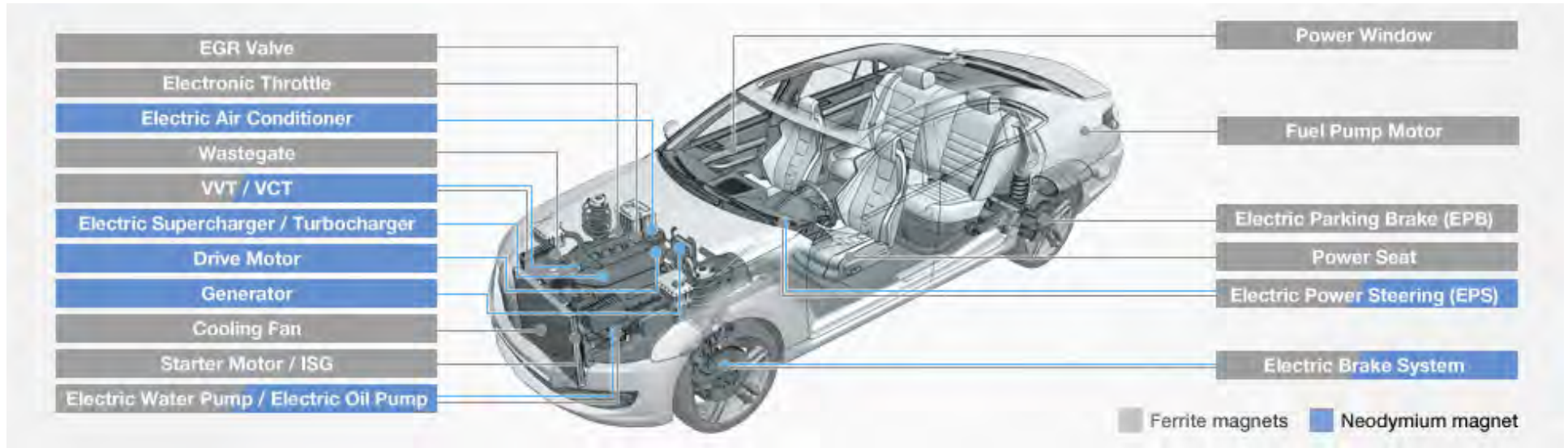

Source: TDK: https://product.tdk.com/info/en/products/magnet/technote/ap_automotive.html



Technical Meeting and Exhibition
MS&T18
MATERIALS SCIENCE & TECHNOLOGY

October 14-18, 2018
Columbus, Ohio, USA



Current And Future Major Applications

- **Hybrid and electric cars & trucks are in a rapid growth phase:**
 - 2018 forecast 25 million units.
 - 18,000 tonnes of REPM's in 2020.
 - Forecast to be largest consumer of RE magnets by 2025.
- **Electric bicycles is another large and growing application:**
 - Estimated 13,000 tonnes in 2020
- **HDD (servers, cloud storage):**
 - Future demand flat to declining.
 - 9,000 tonnes in 2018



Source: Magnetics and Materials LLC, WTBenecki LLC, numerous industry sources



Current And Future Major Applications

- **Direct Drive wind turbines:**
 - RE magnet weight forecast in 2020 is 25,000 tonnes.
- **Automotive (ICE):**
 - Over 100 PM devices in a typical car.
 - Estimated 12,000 tonnes usage in 2020.
- **General industrial and commercial motors for robotics, appliances, HVAC etc.**
- **Acoustic transducers.**
- **Magneto caloric cooling for refrigeration and HVAC is a potential major application.**

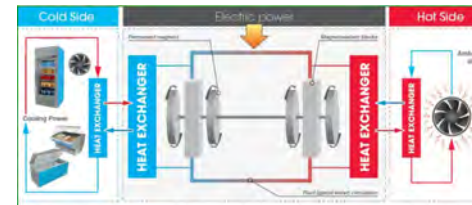

Source: Magnetics and Materials LLC, WTbenecki LLC, numerous industry sources



Technical Meeting and Exhibition
MS&T18
MATERIALS SCIENCE & TECHNOLOGY

October 14-18, 2018
Columbus, Ohio, USA



Outline

- **Markets And Applications**
- **PM Principles – Back to Basics**
- **REPM History**
- **Current Materials And Technologies.**
 - **Powder Metallurgy**
 - **Melt Spinning**
 - **Dy Diffusion**
 - **Hot Pressing**
 - **SmFeN**
 - **La-Co Ferrite**
- **Future trends**
 - **Toyota**
 - **3D Printing**
- **Final thoughts**



The Three Magnetic Vectors

- **H - Magnetic field (from current).**
- **B - Magnetic flux density or Induction.**
- **M – Magnetization (a material property).**
 - These vectors are not independent, but are related.
 - Induction is the combination of magnetization and magnetic field.

Source: Spontaneous Materials, <http://www.spontaneousmaterials.com/>



How Are B, H and M Related?

$$B = H + 4\pi M \quad \text{cgs units}$$

$$B = \mu_0 (H + M) \quad \text{SI units}$$

$$\mu_0 = 4\pi \times 10^{-7} \text{ Tesla-m/A}$$



Hysteresis Loops – Normal and Intrinsic

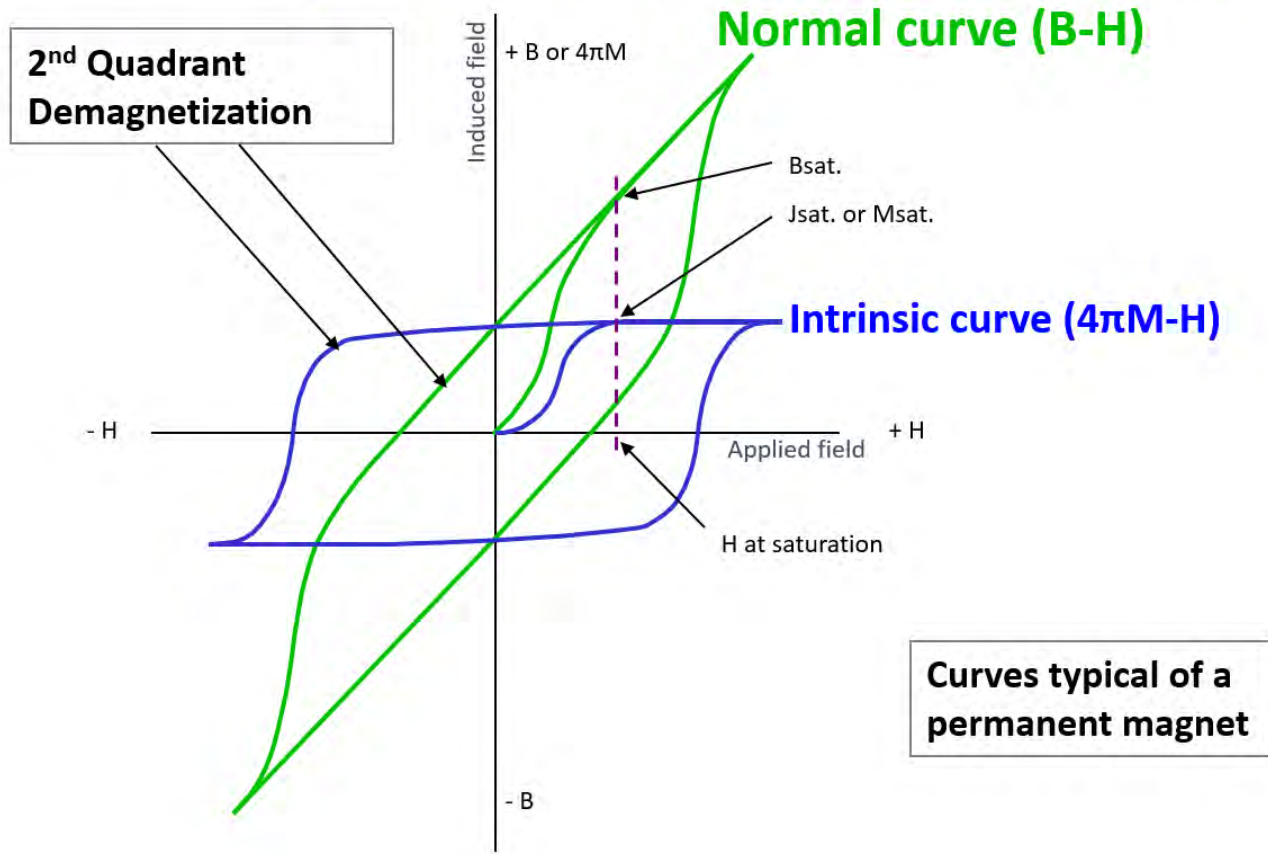

Permanent Magnet Key Characteristics

2nd Quadrant Demagnetization

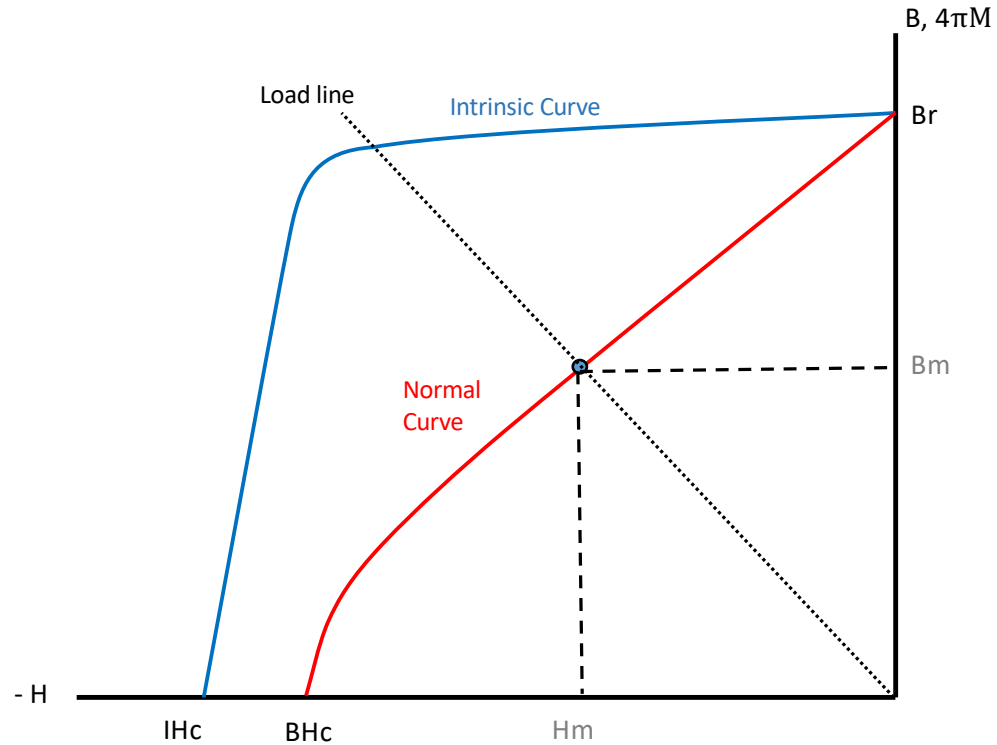

What Is (BH)max?

- $H_g^2 = (B_m H_m) V_m / V_g$ – Hence, V_m is minimum when BH is maximum

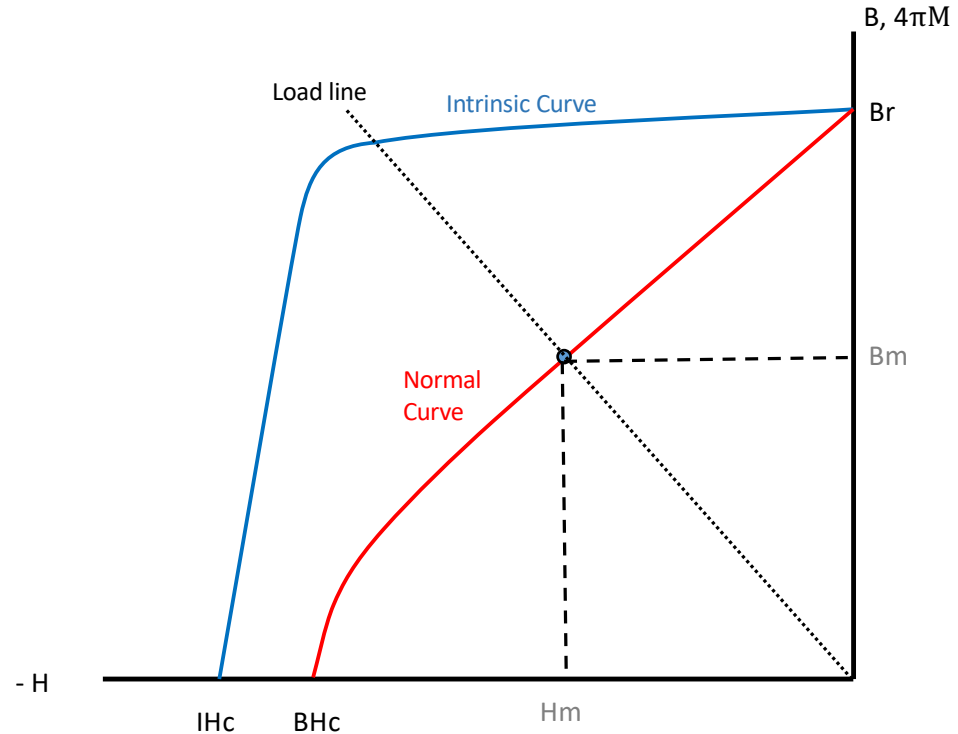
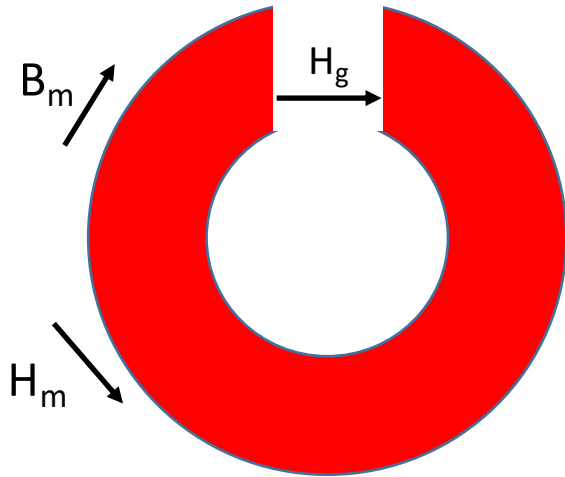

What Is (BH)max?

- $H_g^2 = (B_m H_m) V_m / V_g$

- $E_g = H_g^2 V_g / 8\pi$

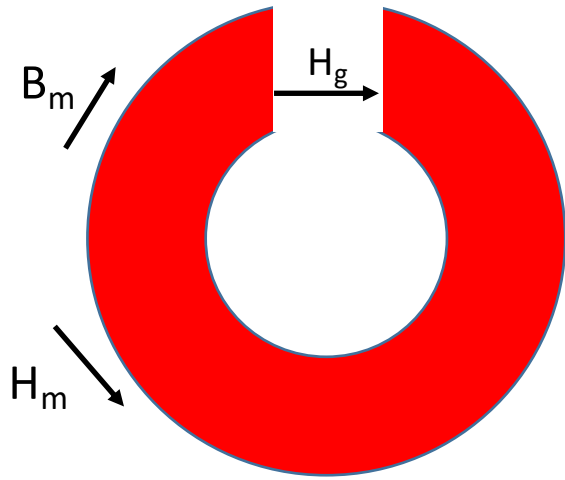

- Hence in order to minimize magnet volume (V_m) the magnet is designed to operate at $(BH)_{max}$.
- It's possible for static applications but not for dynamic applications.
- $(BH)_{max} \rightarrow B_r^2/4$

Many Other Important Characteristics (BH)_{max} Is Only One!

- B_r
- BH_c
- IH_c
- H_k
- Recoil permeability
- Rate of change of B and BH_c with temperature
- Maximum operating temperature
- Ease of magnetizing
- Resistivity
- Mechanical properties
- Machinability
- Shape availability
- Raw material cost and availability
- Corrosion resistance
- Manufacturability and ease of device/sub assembly integration
- Economics of total raw materials and manufacturing process



Outline

- **Markets And Applications**
- **PM Principles – Back to Basics**
- **REPM History**
- **Current Materials And Technologies.**
 - **Powder Metallurgy**
 - **Melt Spinning**
 - **Dy Diffusion**
 - **Hot Pressing**
 - **SmFeN**
 - **La-Co Ferrite**
- **Future trends**
 - **Toyota**
 - **3D Printing**
- **Final thoughts**



New Era Of Permanent Magnets

- **Following the successful development of Alnico magnets, with energy products up to 13 MGOe, future major advances in permanent magnet materials would require shifting emphasis from shape anisotropy to crystal anisotropy.**
- **This led, in the 1960s, to studies to identify anisotropic crystalline phases, preferably hexagonal or tetragonal, which combined high saturation magnetization with high magnetocrystalline anisotropy.**



New Era Of Permanent Magnets

- **Several factors focused attention on rare earth intermetallic compounds.**
 - **First, several of the rare earth elements display magnetic ordering and large magnetic moments at low temperatures.**
 - **Second, it was known that, because of the large difference in atomic radii between the rare earth and Mn, Fe, Co and Ni atoms, there is a tendency to form several intermetallic compounds in the binary systems.**
 - **Third, previous work had shown that many of these intermetallic compounds exhibited magnetic ordering by the coupling of the rare earth magnetic moment with the 3d transition element moment.**



SmCo-Based Permanent Magnets

- In order to be possible candidates for permanent magnet materials, the compounds must combine the basic attributes of:
 - High saturation magnetization
 - Elevated Curie temperature and
 - Large magnetocrystalline anisotropy with a magnetically unique crystallographic axis.
- All these considerations were found to narrow the group of binary compounds from to RCo_5 and R_2Co_{17} with $R = Y, Ce, Pr, Nd$ or Sm .
- This led to the development of commercial Sm-Co magnets based on the binary $SmCo_5$ (nucleation controlled) or multicomponent Sm_2Co_{17} (domain wall pinning) systems.

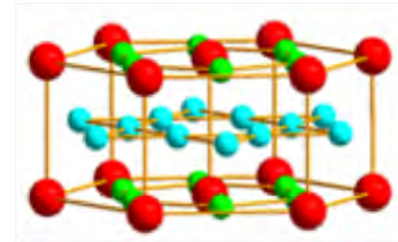

SmCo₅ Crystal Structure

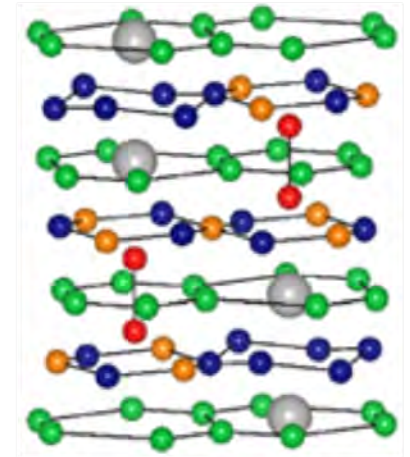

Sm₂Co₁₇ Crystal Structure

The NdFeB Era

- **Historically, the development of RFe-based permanent magnets, by powder metallurgical processing, has been hindered for several reasons:**
 - **First, Fe forms much fewer intermetallic compounds with the rare earths than Co.**
 - **Second, stable compounds of the RFe₅ composition are absent.**
 - **Third, compounds which are stable, e.g. R₂Fe₁₇, have low Curie temperatures and planar preference anisotropy.**



The NdFeB Era

- By a strange coincidence permanent magnets based on the $\text{Nd}_2\text{Fe}_{14}\text{B}$ tetragonal compound were discovered, and the key inventive claims were filed, during 1982 by both General Motors Corporation (GMC) and Sumitomo Special Metals Corporation (SSMC). SSMC was later to form a JV with Hitachi and eventually merged as Hitachi Metals in 2007. GMC spun off the NdFeB magnet business as Magnequench; today part of Neo Performance Materials.
- The Hitachi process is based on powder metallurgical processing whereas the Magnequench process is based on melt spinning or jet casting.

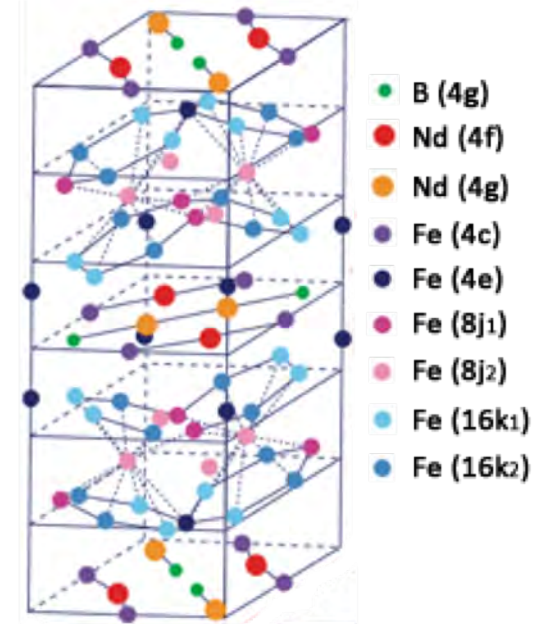

$\text{Nd}_2\text{Fe}_{14}\text{B}$ Crystal Structure

Outline

- **Markets And Applications**
- **PM Principles – Back to Basics**
- **REPM History**
- **Current Materials And Technologies.**
 - **Powder Metallurgy**
 - **Melt Spinning**
 - **Dy Diffusion**
 - **Hot Pressing**
 - **SmFeN**
 - **La-Co Ferrite**
- **Future trends**
 - **Toyota**
 - **3D Printing**
- **Final thoughts**



Generic Powder Metallurgical Processing of REPM's

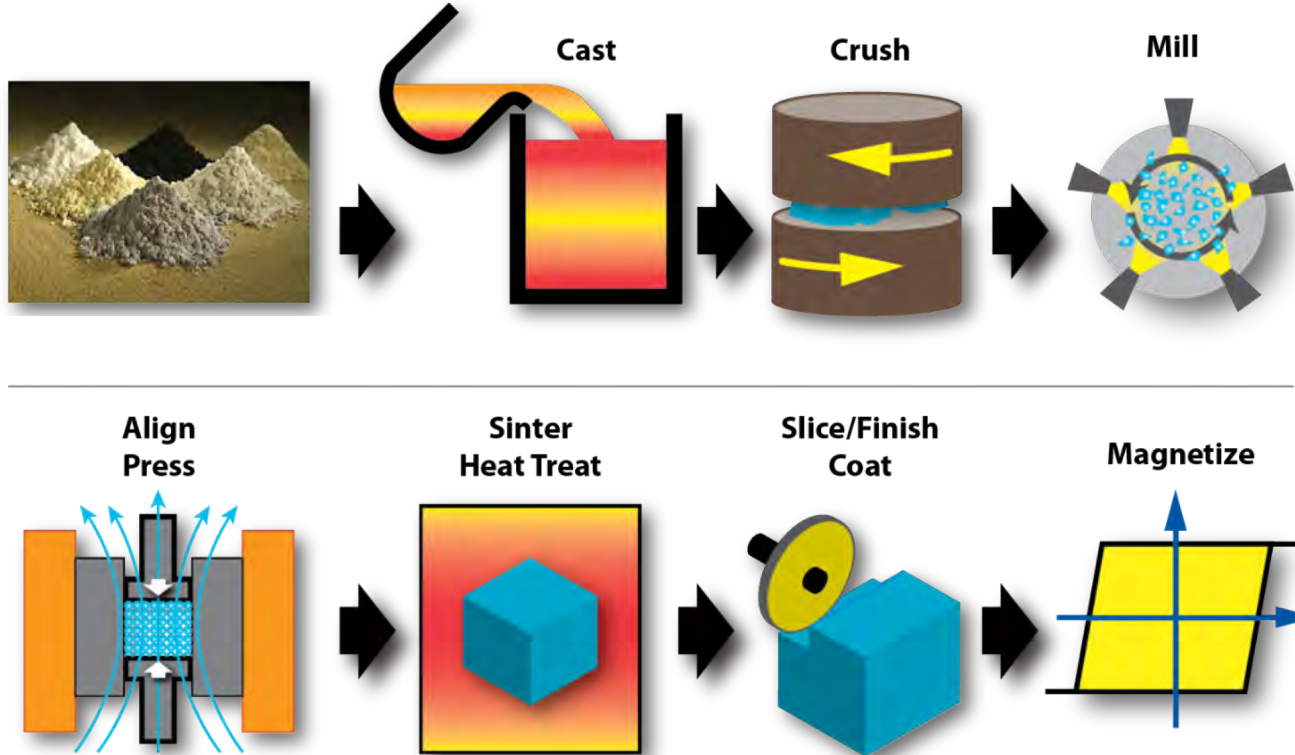

Typical Powder Metallurgical Processing of NdFeB

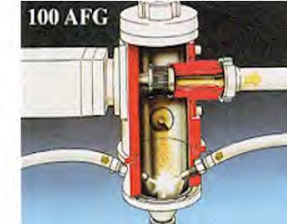
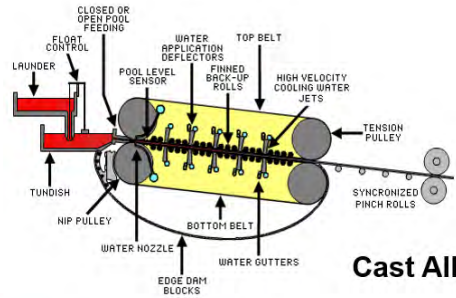

Cast Alloy → H₂ Decrepitate (NdFeB) → Mill to fine powder

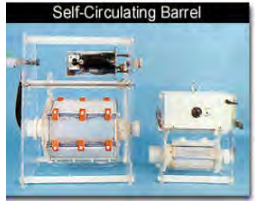

Coat
Nickel Plate
E-coat
Many others

Finish Grind

Press powder

Sinter & Anneal

Typical Electrocoat System

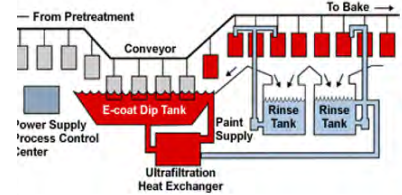

Source: Magnetics and Materials LLC, <https://www.magmatllc.com/index.html>



MS&T18
MATERIALS SCIENCE & TECHNOLOGY

October 14-18, 2018
Columbus, Ohio, USA



Melt Spinning (Jet Casting) Of NdFeB

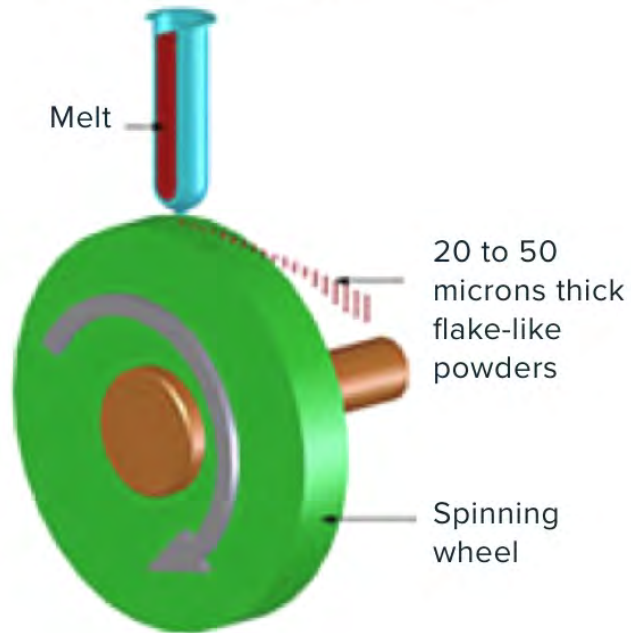

- This method of melt-spinning consists of melting the alloy or elements in a tube either under vacuum or inert gas. The melt, under argon pressure, is sprayed through an orifice in the tube onto a rotating, water-cooled copper wheel or disc. Cooling rates in excess of 10^6 K/s are achieved.
- GM commercialized this technology for the production of magnets, known as Magnequench.
- The isotropic powders are mainly used in bonded magnet production.

Demagnetization Behavior At Temperature for NdFeB (N55M)

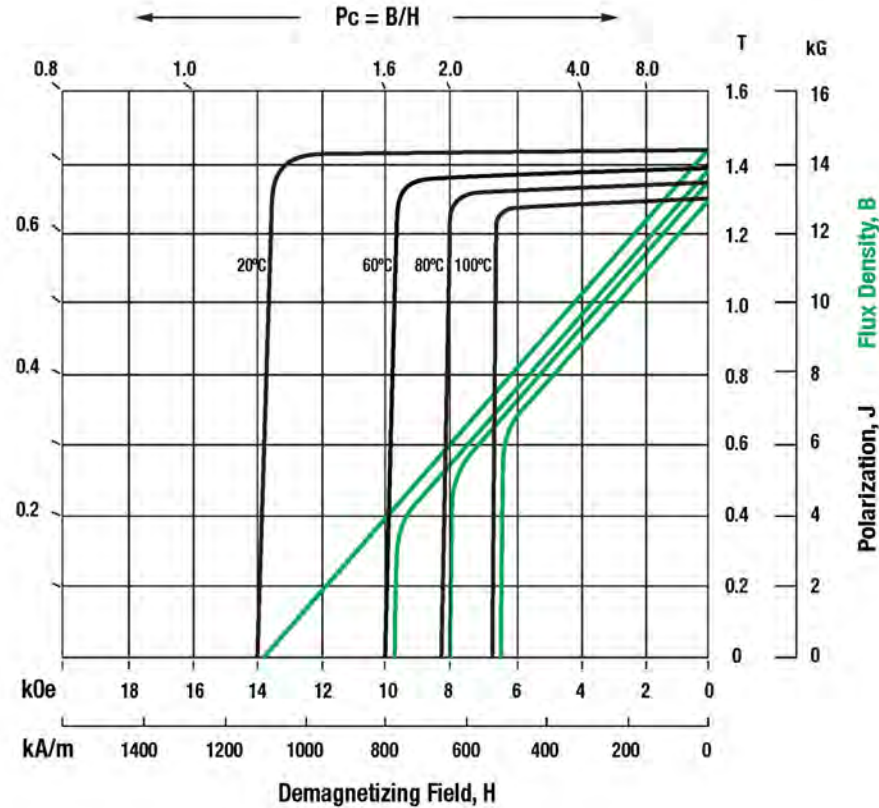

Effect Of Dy On Coercivity

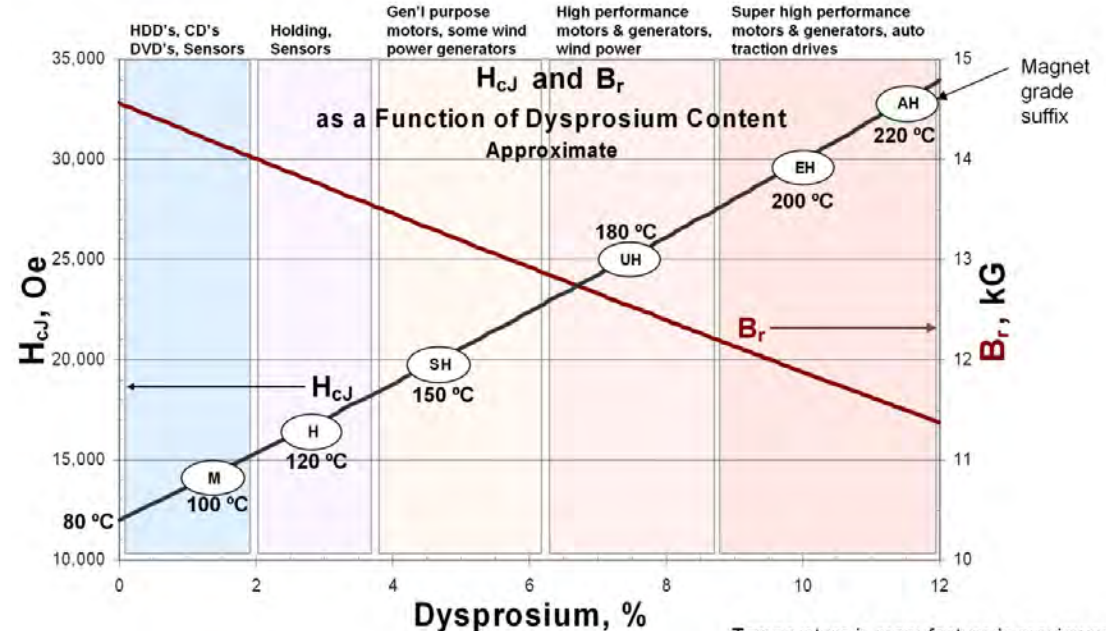
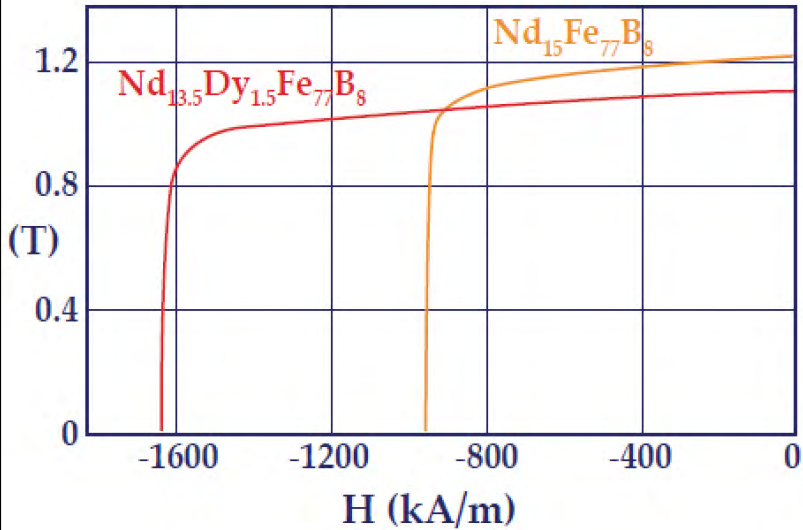

Reference: IEEE Transactions on Magnetics, Volume 20, Issue 5, September 1984, pp. 1584-1589

Source: Magnetics and Materials LLC, <https://www.magmatllc.com/index.html>



Technical Meeting and Exhibition
MS&T18
MATERIALS SCIENCE & TECHNOLOGY

October 14-18, 2018
Columbus, Ohio, USA



Rare Earth Price And Supply Disruption

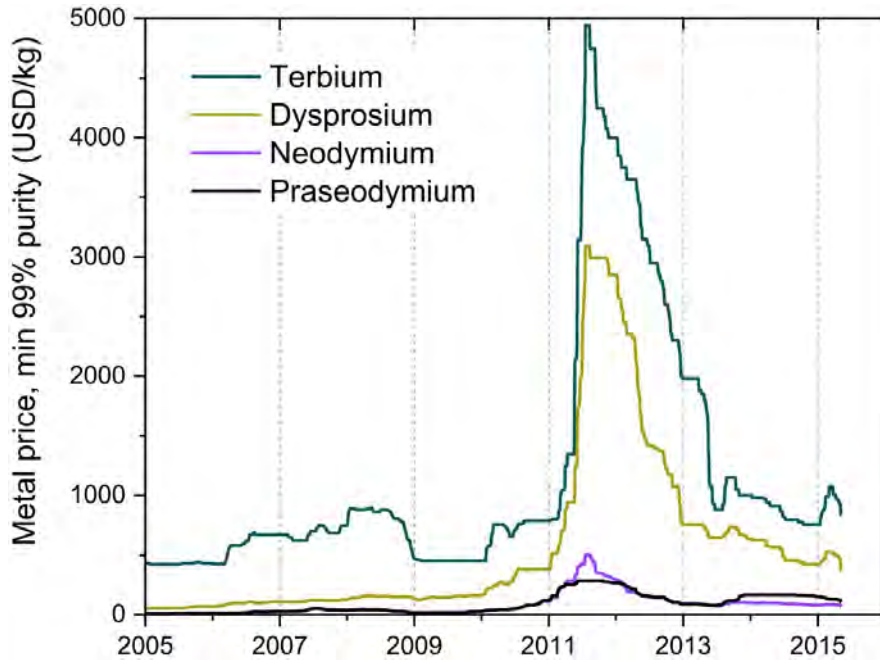

- Rare Earth prices spiked in 2011/2012 e.g. Dy₂O₃ price increased 50 fold.
- Major investment in search for RE-free substitution and application redesign.
- Drove efforts to reduce Dy content for higher temperature/coercivity grades

Reference: Resources Policy, Volume 52, June 2017, Pages 349-357



Technical Meeting and Exhibition
MS&T18
MATERIALS SCIENCE & TECHNOLOGY

October 14-18, 2018
Columbus, Ohio, USA



Dy Diffusion At Grain Boundaries

Enhancement of coercivity with small degradation of remanance by diffusing HREE into grain boundary phases and surfaces of grains

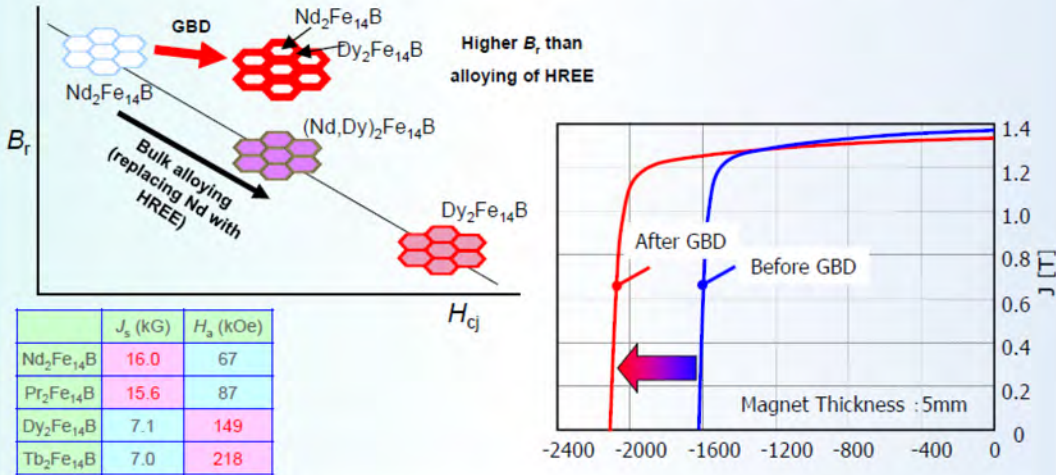

GBD can increase H_{cj} with minimum decrease in B_r .

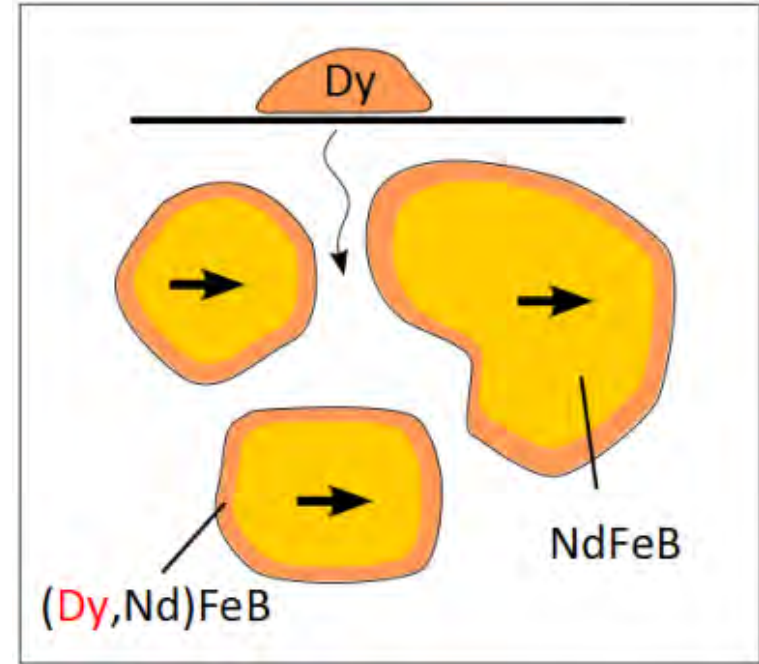

Reference: Yotaka Yoshida, Daido Steel, Magnetics 2016.



Hot Deformed Radially Oriented Rings

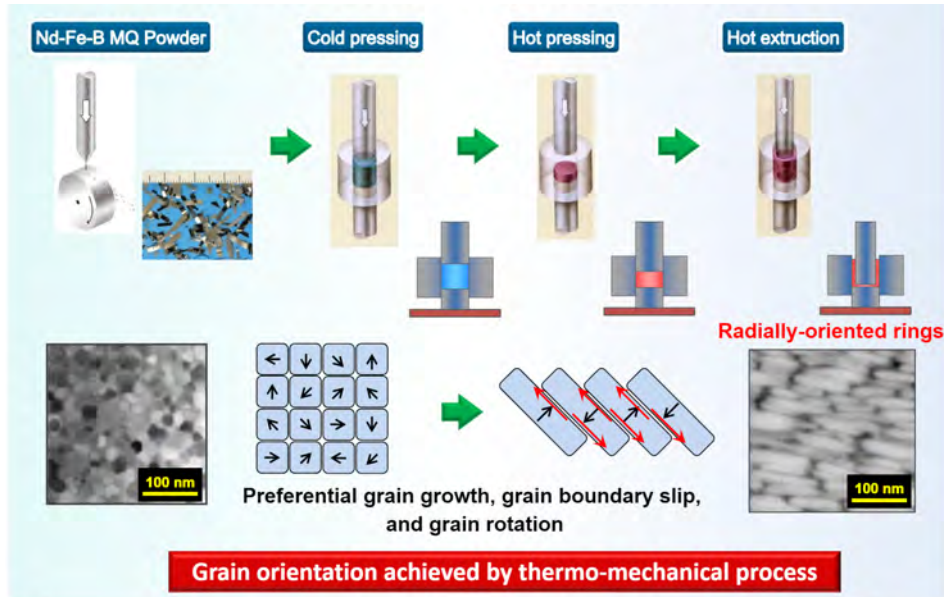

Daido Steel and Honda Adopt World's First Hybrid Vehicle Motor Magnet Free of Heavy Rare Earth Elements

— Honda Freed, on sale this fall, will be the first hybrid vehicle to adopt new magnet —

July 12, 2016, Japan Automobile



TOKYO, Japan, July 12, 2016 - Daido Steel Co., Ltd. and Honda Motor Co., Ltd. became the world's first companies to achieve practical application of a hot deformed neodymium magnet containing no heavy rare earth¹ and yet with high heat resistance properties and high magnetic performance required for the use in the driving motor of a hybrid vehicle. This heavy rare earth-free hot deformed neodymium magnet will be applied first to the all-new Honda FREED, scheduled to go on sale this fall.

Reference: Yotaka Yoshida, Daido Steel, Magnetics 2016.



Technical Meeting and Exhibition
MS&T18
MATERIALS SCIENCE & TECHNOLOGY

October 14-18, 2018
Columbus, Ohio, USA



Dy Content versus Coercivity At 180 C

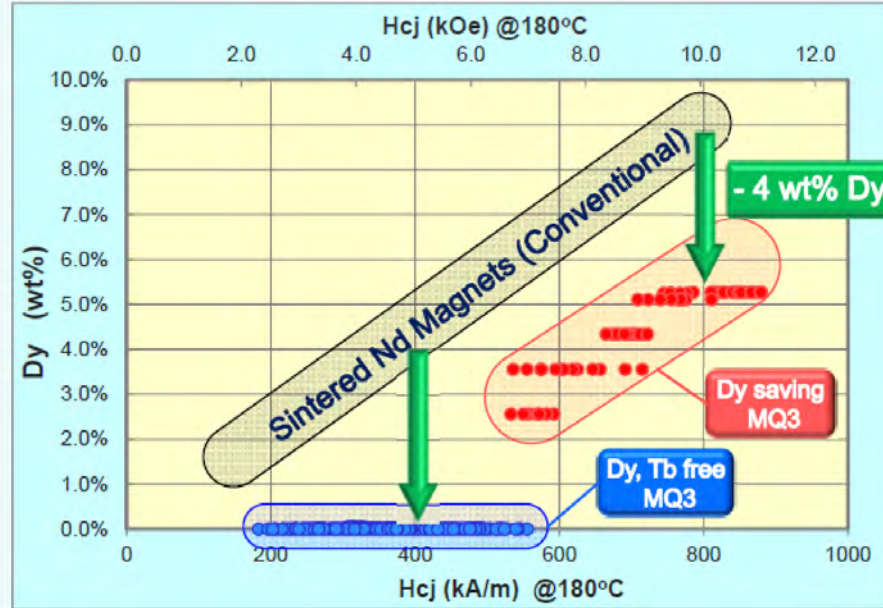

Approx. 4wt% less Dy is needed to achieve same H_{cj} as sintered Nd

Reference: Yotaka Yoshida, Daido Steel, Magnetics 2016.



Sm-Fe-N Magnets

- Sm-Fe-N alloy is a promising candidate for high-performance permanent magnets.
- The $\text{Sm}_2\text{Fe}_{17}\text{N}_3$ intermetallic compound, which exhibits high saturation magnetization with a large anisotropy field and a high Curie temperature.
- $\text{Sm}_2\text{Fe}_{17}\text{N}_3$ intermetallic compound has been prepared by the production of $\text{Sm}_2\text{Fe}_{17}$ alloy powder and subsequent nitrogenation of the powder by a gas-solid reaction. The resultant $\text{Sm}_2\text{Fe}_{17}\text{N}_3$ intermetallic compound has thus been produced in powder form for bonded magnets.

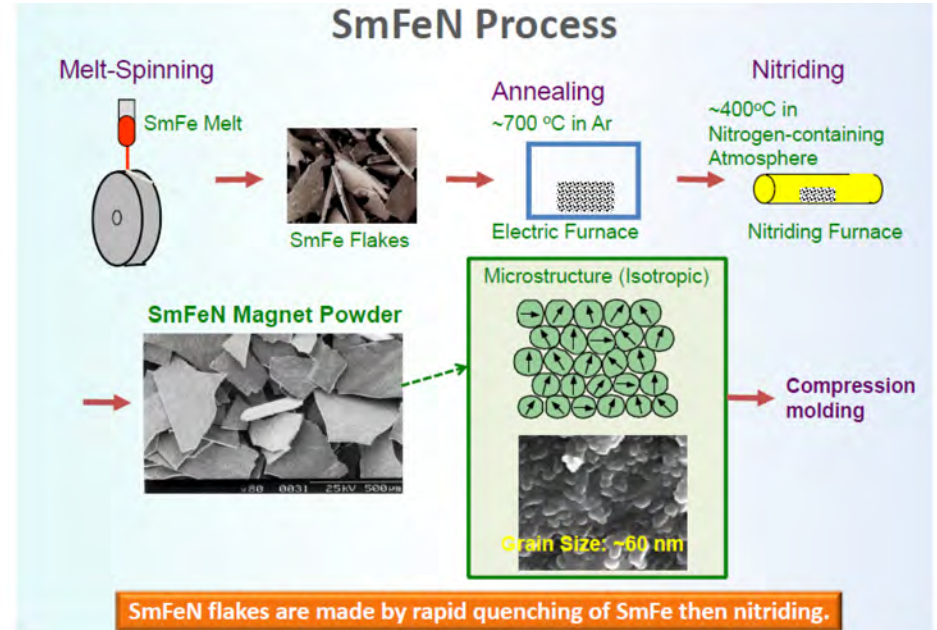

Reference: Yotaka Yoshida, Daido Steel, Magnetics 2016.

La-Co Doped Hard Ferrite Magnets

- Ever since their discovery by Philips between 1952 and 1956, M-type ferrites have increasingly become widely used in many applications.
- Both saturation magnetization as well as magnetocrystalline anisotropy of M-type ferrite fine particles can be modified by the substitution of rare earths.

The highest level magnetic properties available in a mass-produced ferrite magnets (As of Mar. 2018)

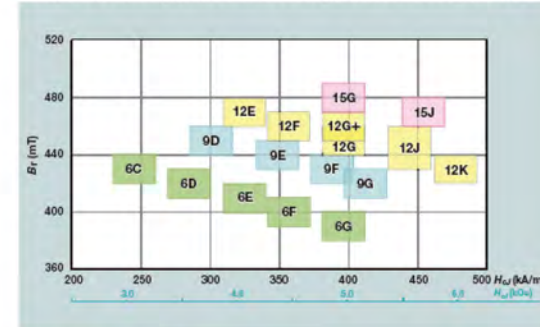

主要材質の減磁曲線 NMF-15 シリーズ Demagnetization Curves of NMF-15 Series

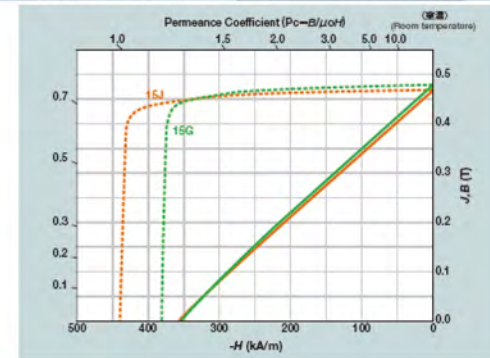

Source: Hitachi Metals, <http://www.hitachi-metals.co.jp/e/products/auto/el/pdf/hg-a27-i.pdf>



Technical Meeting and Exhibition
MS&T18
MATERIALS SCIENCE & TECHNOLOGY

October 14-18, 2018
Columbus, Ohio, USA



Outline

- **Markets And Applications**
- **PM Principles – Back to Basics**
- **REPM History**
- **Current Materials And Technologies.**
 - **Powder Metallurgy**
 - **Melt Spinning**
 - **Dy Diffusion**
 - **Hot Pressing**
 - **SmFeN**
 - **La-Co Ferrite**
- **Future trends**
 - **Toyota**
 - **3D Printing**
- **Final thoughts**



The Toyota Magnet Announcement

Toyota Motor Corporation

Toyota Develops New Magnet for Electric Motors Aiming to Reduce Use of Critical Rare-Earth Element by up to 50%

- World's first neodymium-reduced, heat-resistant magnet developed by Toyota
- Key element of the foundation required to popularize electrified vehicles

Toyota City, Japan, February 20, 2018—Toyota Motor Corporation (Toyota) announces that it has developed the world's first¹ neodymium-reduced, heat-resistant magnet. Neodymium magnets are used in various types of motors such as the high-output motors found in electrified vehicles, use of which is expected to increase rapidly in the future. The new magnet uses significantly less neodymium, a rare-earth element² ("rare earth"), and can be used in high-temperature conditions.



The Toyota Magnet Announcement

Development point 1: Grain refinement of magnet

15

Grain refined to 1/10th the size of a conventional magnet grain, enlarging the grain boundary area

- Magnets consist of numerous fine grains. Smaller grains have a larger boundary area for coercivity enhancement
- As the motor load increases, the temperature of the magnet rises, and the magnetic force of magnet decreases

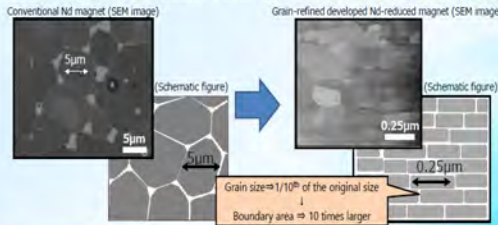

Improved magnetization and coercivity through refinement of each grain of the magnet and enlarging the boundary area (Patent filed in 2010)

Rewarded with a smile

TOYOTA

Development point 2: Two-layered high-performance grain surface

16

Two-layered structure by thickening of Nd at grain surface with surface-modification heat treatment

- Simple substitution of Nd to LREE causes deterioration of properties (magnetization and coercivity)
- Retention of magnetic force through the creation of a layer with a high density of Nd on the surface of the grain
- Maintaining coercivity by thinning (reducing the amount of) the Nd inside the grain and mixing alternative LREE

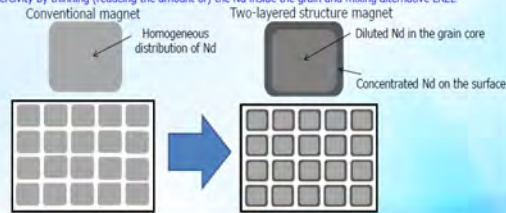

Through the two-layered structure, both the reduction of Nd usage and maintenance of high performance are possible (Patent filed in 2013)

Development point 3: Specific alloying ratio of La and Ce

Alloying specific ratio of La and Ce suppresses performance deterioration

- Usage of La and Ce, which are abundant and inexpensive
- Simply alloying La and Ce reduces performance (heat resistance and magnetization)

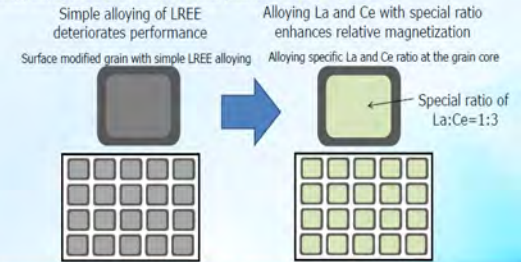

Alloying La and Ce at the special ratio suppresses performance deterioration even with reduced Nd (Patent filed in 2017)

- Appears to be La/Ce substituted alloy with a fine grained (melt spun) microstructure achieving enhanced coercivity.
- Similar to Dy-diffusion processing Nd is concentrated at the grain boundaries.

Additive Manufacturing/3D Printing of Bonded Magnets

- Additive Manufacturing refers to a process by which digital 3D design data is used to build up a component in layers by depositing material. The term "3D printing" is increasingly used as a synonym for Additive Manufacturing.
- AM can form complex shapes requiring little or no tooling and post-processing thus reducing the amount of waste generated.
- Work performed at Oak Ridge National Laboratories, TN.

Big Area Additive Manufacturing of NdFeB Bonded Magnets

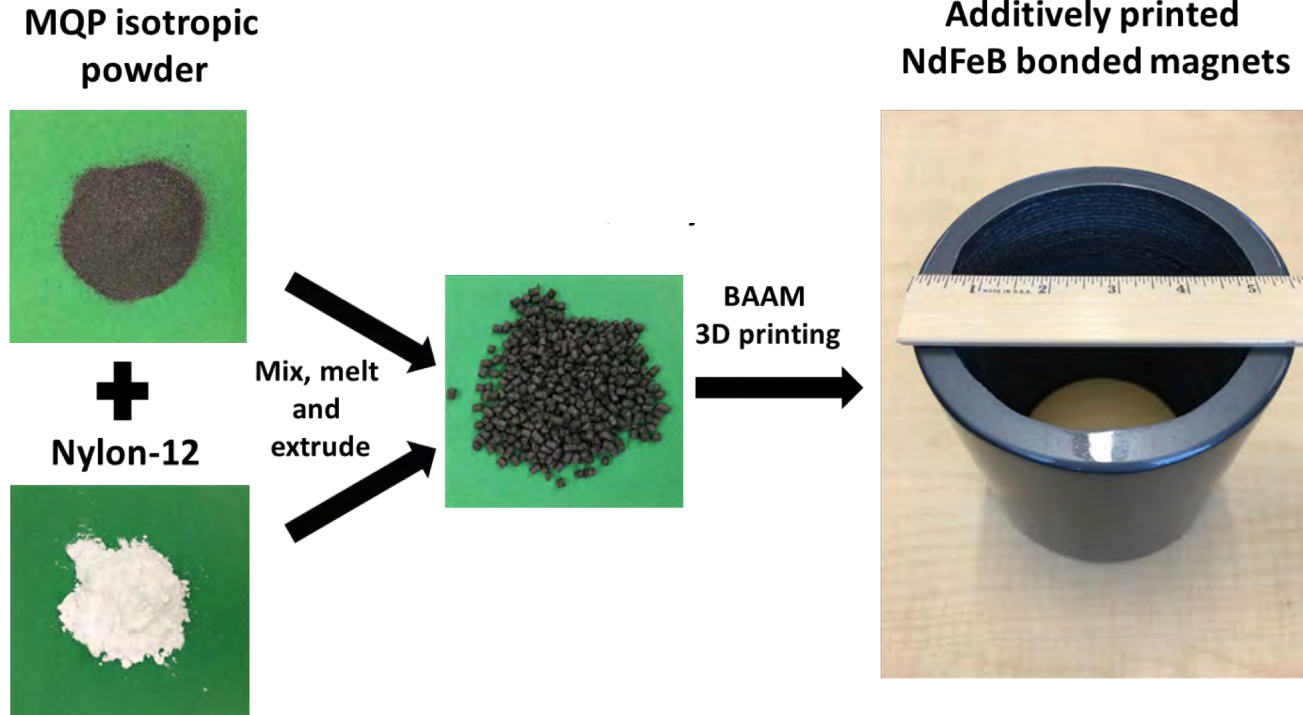

Reference: Li, L. et al. Big Area Additive Manufacturing of High Performance Bonded NdFeB Magnets. Sci. Rep. 6, 36212

BAAM versus IM Magnetic Properties

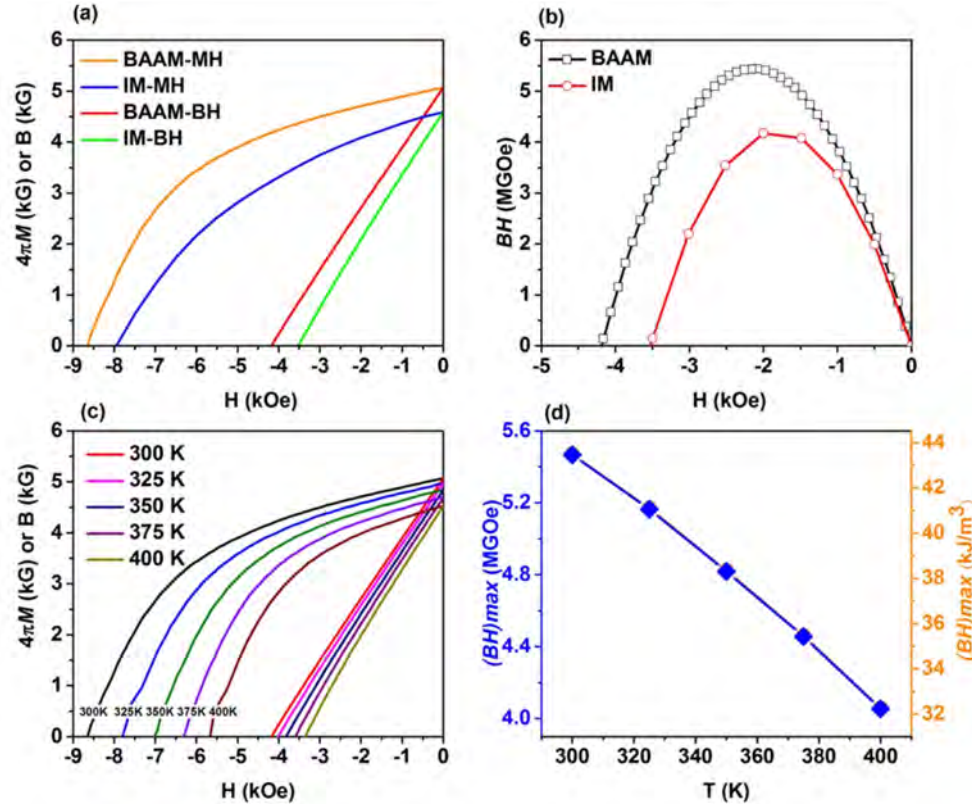

Reference: Li, L. et al. Big Area Additive Manufacturing of High Performance Bonded NdFeB Magnets. Sci. Rep. 6, 36212

Big Area Additive Manufacturing (BAAM) of NdFeB Bonded Magnets Surprise – you can make big magnets!

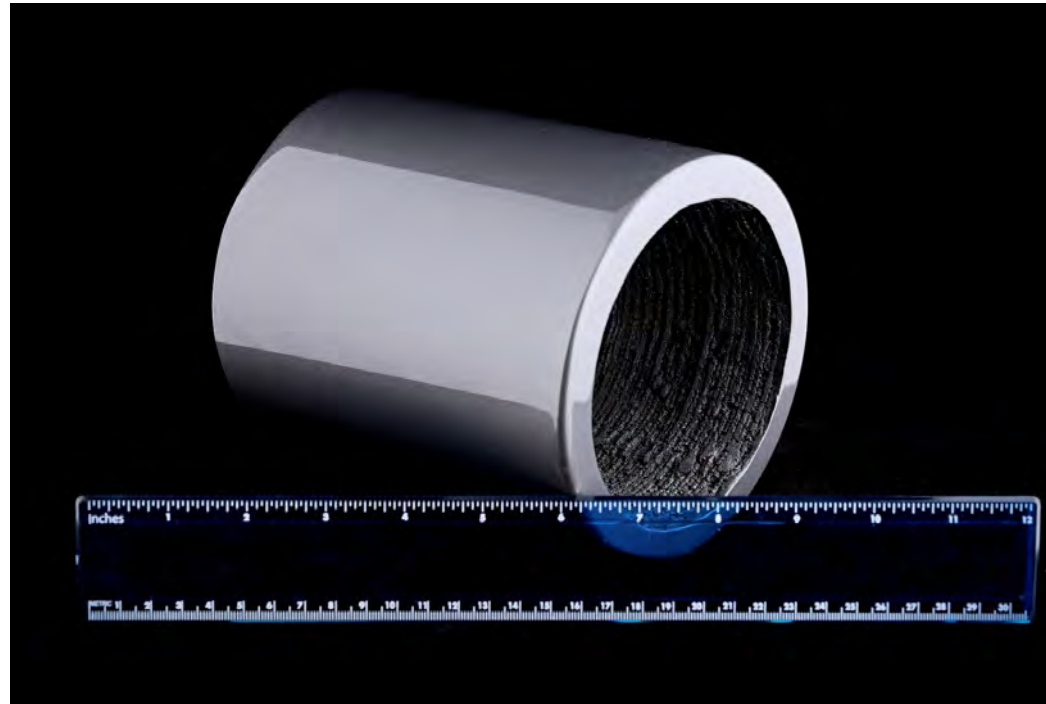

Reference: Li, L. et al. Big Area Additive Manufacturing of High Performance Bonded NdFeB Magnets. Sci. Rep. 6, 36212

OAK RIDGE
National Laboratory



Technical Meeting and Exhibition
MS&T18
MATERIALS SCIENCE & TECHNOLOGY

October 14-18, 2018
Columbus, Ohio, USA



Outline

- **Markets And Applications**
- **PM Principles – Back to Basics**
- **REPM History**
- **Current Materials And Technologies.**
 - **Powder Metallurgy**
 - **Melt Spinning**
 - **Dy Diffusion**
 - **Hot Pressing**
 - **SmFeN**
 - **La-Co Ferrite**
- **Future trends**
 - **Toyota**
 - **3D Printing**
- **Final thoughts**



Is There An Optimum Price-Performance Metric?

Material	Average $(BH)_{max}$ (MGOe)	Average price (\$/kg)	Price/Performance (\$/kg per MGOe)	Market %
NdFeB	40	75	1.9	60
Ferrite	3.8	7.1	1.9	31
Bonded NdFeB	8	90	11.3	5
SmCo	25	100	4.0	2
Alnico	7	58	8.3	2



Niche And Mass Market Materials

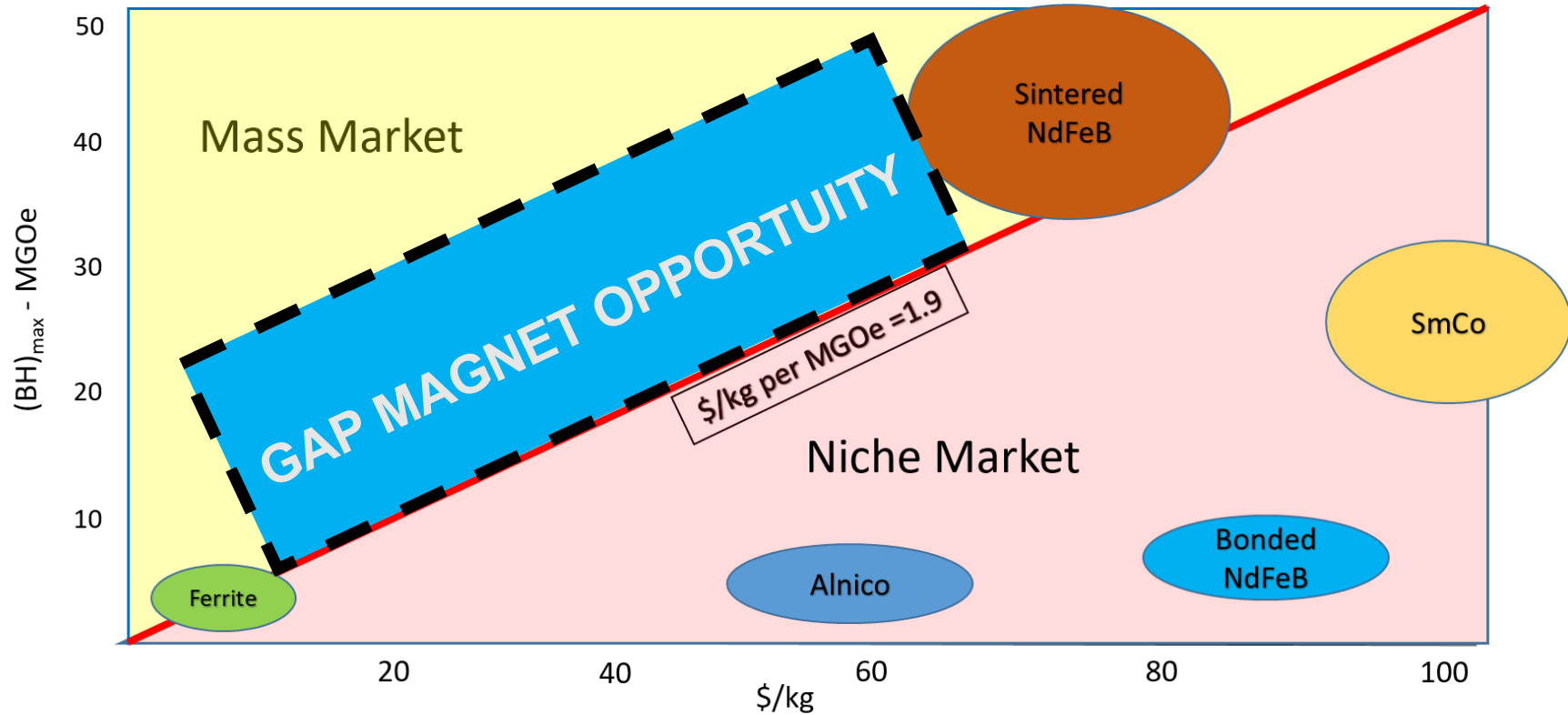

Thank you for your attention Any Questions?



Dr. John Ormerod

Senior Technology Advisor

Magnet Applications, Inc.

DuBois, Pennsylvania, USA

<http://www.magnetapplications.com/>

<https://www.linkedin.com/in/jormerod/>

+1 414 899 2859

John_ormerod@magnetus.com

